

James Walker®

Heavy Duty Hydraulic Sealing Products

Issue 1



High Performance Sealing Technology



Introduction

Customer support

When you select one of our many sealing products, you immediately get the full expertise of James Walker on your side — wherever in the world you may be.

We aim to supply you with the very best:

- Customer service.
- Technical support.
- Fluid sealing products.
- Delivery.
- After sales service.



Our high technology Customer Support Centre leads the fluid sealing industry with its service to tens of thousands of customers worldwide.

On-site technical advice comes from our professional field engineers and industry sector specialists. With the backing of our James Walker Technology Centre, they are able to solve virtually any fluid sealing problem for our customers.

Surety of supply

Surety of supply is vitally important to the vast majority of our customers. This is especially true when maintenance engineers are tackling a plant breakdown or an OEM is working to a JIT schedule.

We meet such demands by means of:

- Our worldwide network of companies and distributors covering 100 countries, supported by a secure web-based and highly developed logistics operation.
- Vast range of fluid sealing products held in stock for rapid dispatch.
- Over 100,000 mould tools for express manufacture of non-stocked items.

Non-standard seals

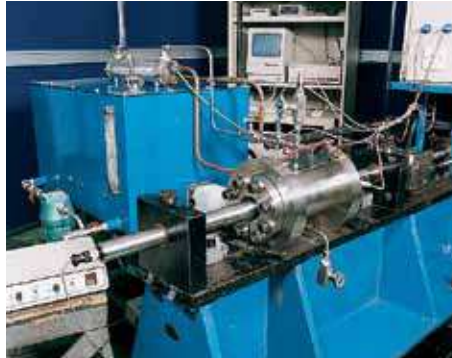

The design and manufacture of non-standard seals is a James Walker speciality. This is undertaken by highly experienced engineers, materials scientists and production personnel. Together, they can solve your sealing problems associated with:

- Worn rams and other components.
- Refurbished or re-machined shafts.
- Out-of-tolerance housings.
- Old plant for which seals are now difficult to source.

In addition we will design, prototype and perfect new sealing systems to match precisely the requirements of hydraulic systems that are under development or need to be upgraded.

In this case, the benefits we offer include:

- Innovative design capability.
- Fullest knowledge of seal, elastomer and engineering plastics technology.
- Advanced design, finite element analysis and prototyping capabilities.
- In-house static, dynamic, thermal and RGD (rapid gas decompression) test facilities.
- An ability to simulate closely the true operating conditions of plant and equipment.

Only when both the James Walker Technology Centre and our client are fully satisfied with test rig results will the new sealing system be subjected to field trials on a working plant.

Sealing kits

We supply complete sealing kits to order. These contain all the products needed for the assembly, maintenance or refurbishment of a specific hydraulic assembly.



Kits can be custom-branded and over-printed with dedicated part numbers to simplify end-user ordering, stocking and issuing routines.

James Walker quality

Quality is the watchword at every James Walker manufacturing plant and customer support location worldwide.

We start with the best raw materials and use advanced production techniques, with strict quality control at every stage, culminating in an exacting finished part inspection.

Our quality systems are third party registered to BS EN ISO 9001:2008 and BS EN 9100:2003.



We are also regularly assessed and quality approved by a wide range of industry bodies and individual customers — including multinational corporations, utilities and government organisations.

Chevron®

Universally Proven Multi-lip Packing

Rod/gland & piston seal

Maximum operating pressure 42MPa (420bar)

Maximum surface speed 0.5m/s

Temperature range -20°C to +120°C

(+100°C below 250mm OD)

Supplied Split & Endless

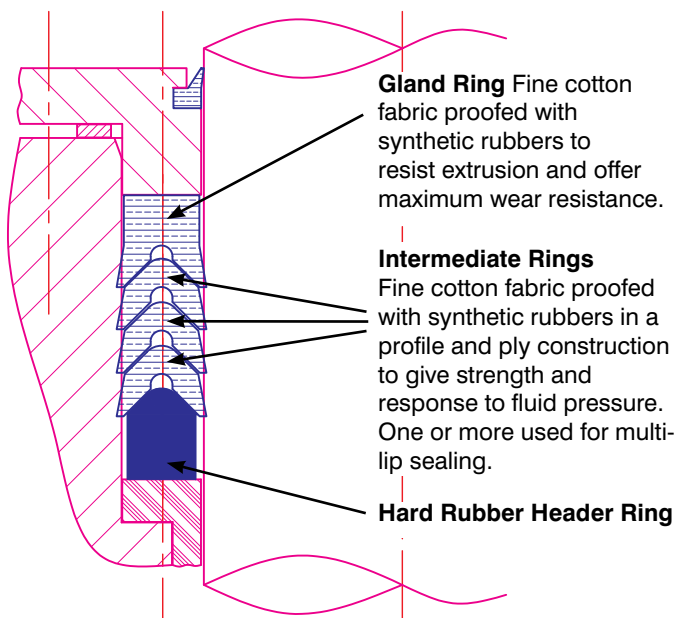

- Highly proven universal lip packing.
- Options to fit adjustable and non-adjustable housing lengths.
- Suits adverse mechanical conditions.
- Header and gland ring of acetal below 250mm OD.
- Available with Self-aligning Gland Ring.
- Spring-loaded header option for wear compensation.

Chevron® packing (known as Shallex® in some regions) is designed to be used in housings with fixed axial length relying on a small initial axial compression.

By controlling the free packing depth in manufacture to take account of the known increase in axial length that will occur when the packing is constrained radially on assembly, this design philosophy provides optimum seal compression together with controlled friction levels and minimum wear.

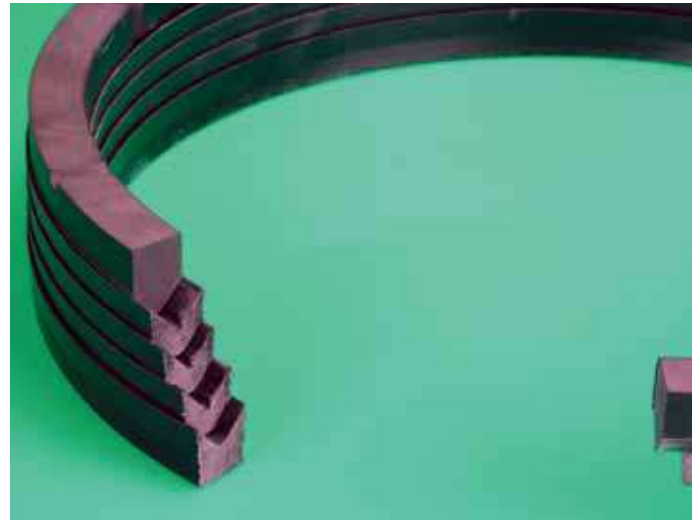

Chevron® with Self-aligning Gland Ring

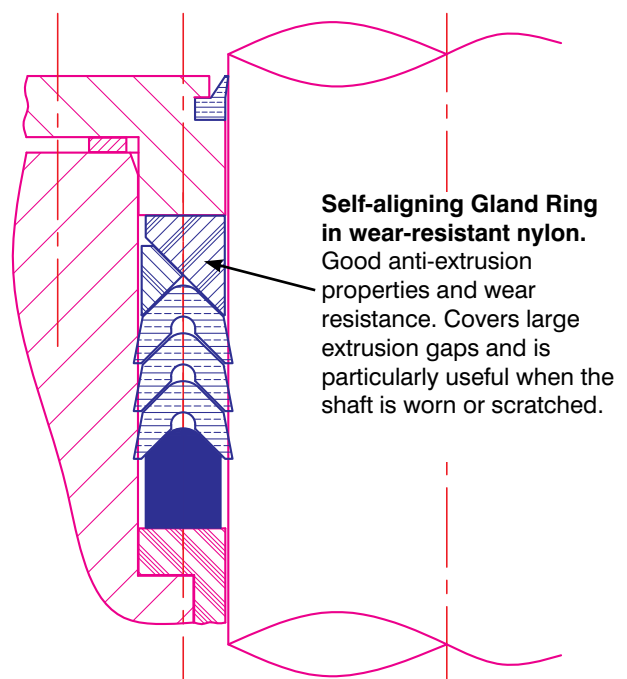

Lofilm®

Lofilm®

Highly Versatile Multi-lip Seal

Rod/gland seal

Maximum operating pressure 42MPa (420bar)

Maximum surface speed 0.5m/s

Temperature range -20°C to +120°C

(+100°C below 250mm OD)

Supplied Split & Endless

- Excellent performance at high and low pressures.
- Very low leakage levels.
- No in-service adjustment required.
- Available with Self-aligning Gland Ring.
- Gland ring of acetal below 250mm OD.

As the name suggests, our Lofilm® multi-lip seal is designed for reliable long-term duties with the absolute minimum thickness of stable fluid film on the dynamic contact surface. The seal comprises a robust gland ring (female adapter), one or more V-shaped intermediate rings, and a header ring. This header ring is a positive seal, precision moulded with a knife-cut sealing edge to give maximum integrity and an annular groove to increase response to applied pressure.

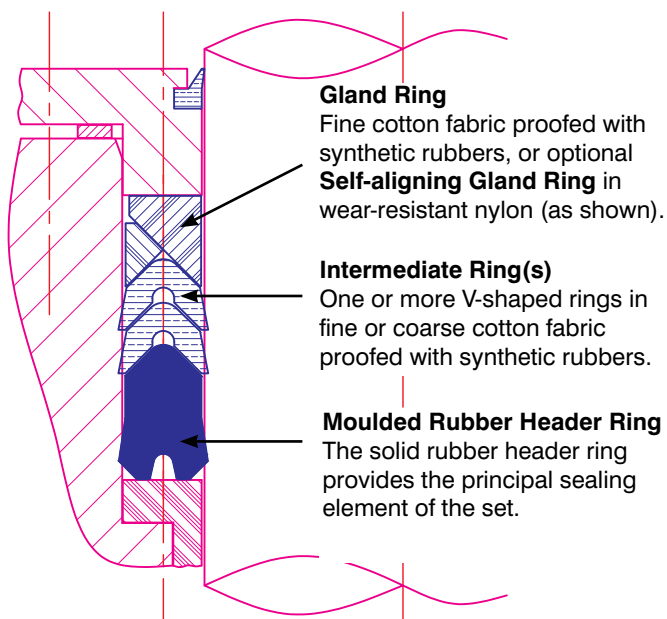

The initial radial interference reduces the fluid film to a minimum over a wide range of operating conditions. The annular groove incorporated in the header increases its response to applied pressure. The rubber sealing lips conform more easily to an uneven surface, worn shafts, etc.



Special features

A versatile rod/gland seal with excellent performance at both low and high pressure due to its responsive header design.

Precision moulded element with knife cut sealing edge to give maximum integrity.

Annular groove is incorporated to increase response to applied pressure.

Rubberised fabric gland to assist anti-extrusion properties with the Self-aligning Gland Ring available as an option.

With its 'dry' running characteristics, Lofilm is the high performance seal most suitable for virtually all types of hydraulic press (main rams and drawback rams), hydraulic cylinder glands and single acting piston heads, and hydraulic valves.

Lion® Expanding Packing

Lion® Expanding Packing

Robust Packing for Heavy Duty Hydraulics

Rod/gland seal

Maximum operating pressure 62MPa (620bar)

Maximum surface speed 0.5m/s

Temperature range -20°C to +100°C

Supplied Split & Endless

- Robust multi-lip packing for heavy duty systems.
- Handles side loads and pressure peaks.
- Available with Self-aligning Gland Ring.

Comparison of the geometry between Chevron® and Lion® Expanding Packing

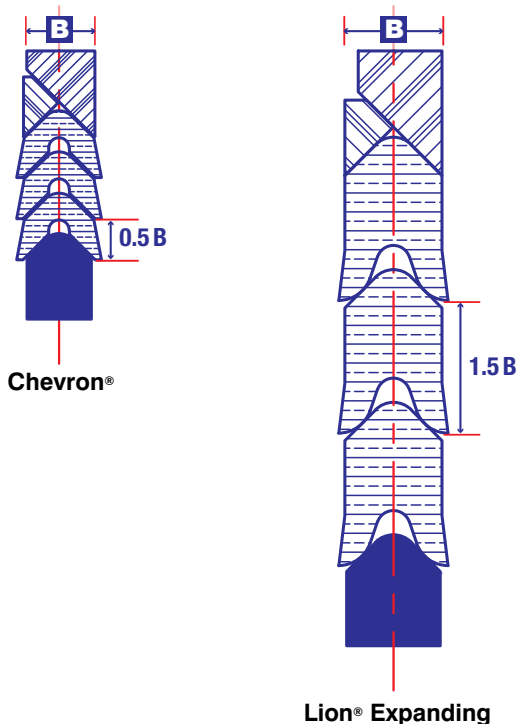

The profile of the sealing lips is suitable in applications where side loads and high pressure peaks are encountered on equipment such as forging presses.

In heavy duty applications the seal is often required not only to effect a seal, but also to provide support to the ram. This 'bearing' role, using deep rings of robust construction to offer radial support to a large ram, has been a successful product feature for many years.



Lion® Expanding Packing with Self-aligning Gland Ring

The Wiper Type L in rubberised fabric is recommended for heavy duty applications

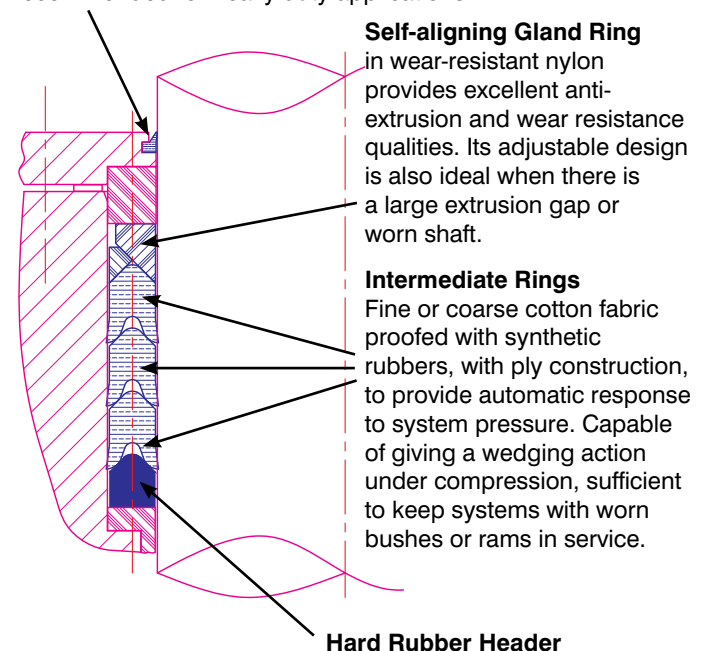

Lofilm® HD

Lofilm® HD

Highly Responsive Heavy Duty Packing

Rod/gland seal

Maximum operating pressure 62MPa (620bar)

Maximum surface speed 0.5m/s

Temperature range -20°C to +120°C

Supplied Split & Endless

- Very robust packing for heaviest duties.
- Recommended for forging and extrusion presses.
- Instant response under all loads.
- High integrity sealing on worn surfaces.
- Available with Self-aligning Gland Ring.

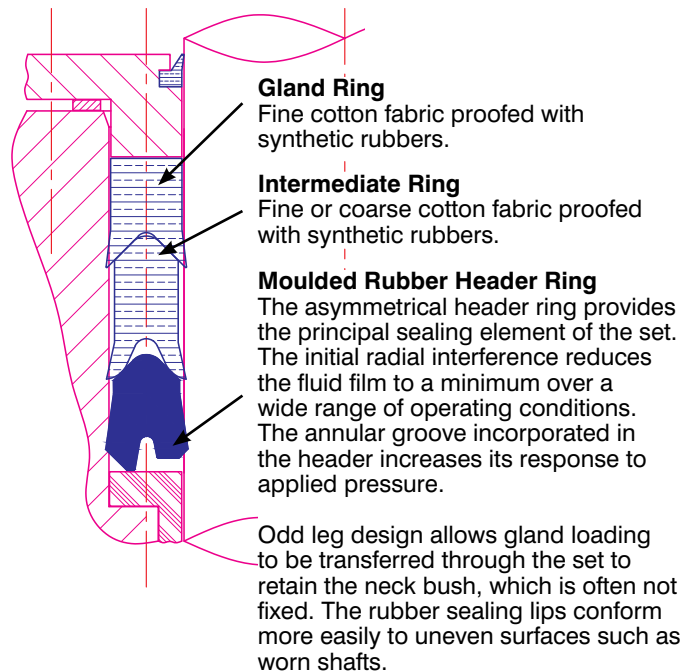
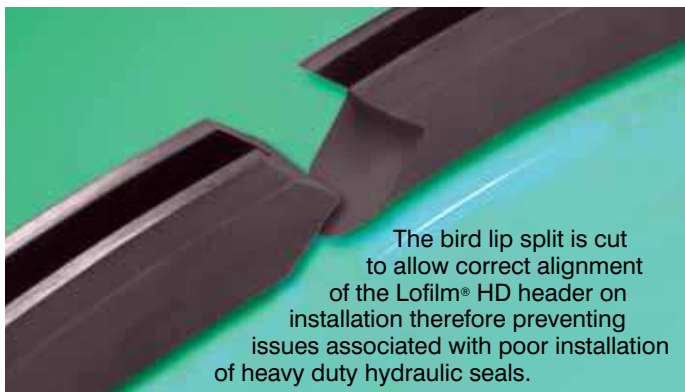

Comparison of the geometry between Lofilm® HD and Lion® Expanding Packing

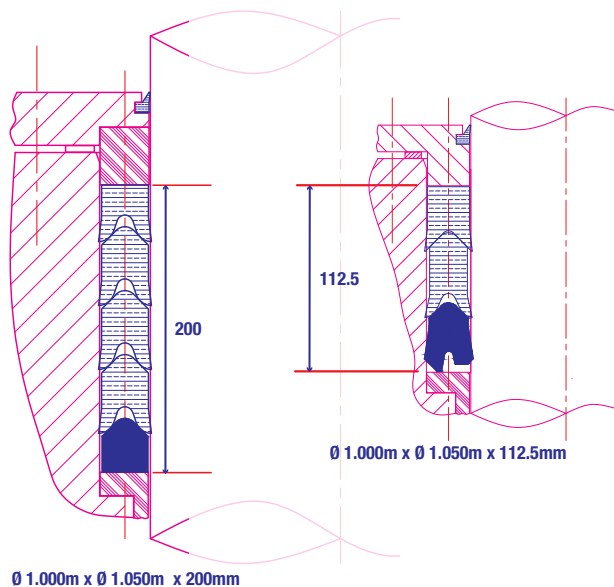

Lion® Expanding

Lofilm® HD

A pressure responsive hydraulic seal specially designed for use in arduous reciprocating gland applications, where fast pressure rises occur and where side loads can be substantial.

Using the experience from Lion® Expanding Packing, Lofilm® HD incorporates a refined design of the deep rings to provide radial support to the ram.

The Lofilm header's ability to reduce the fluid film overcomes potential leakage situations such as the main ram emerging under low pressure and thick film conditions with pressure energisation at a minimum.

Solosele® G

Robust, compact single element seal**Rod/gland & piston seal**

Maximum operating pressure	42MPa (420bar)
Maximum surface speed	0.5m/s
Temperature range	-20°C to +120°C
Supplied endless	

- Excellent performance at high and low pressures.
- Flexible chamfered lips provide high sealing integrity.
- Also Solosele® for horizontal grooves:
robust alternative to 'O' rings on static duties.

Solosele® G is a compact reciprocating rod, gland or single acting piston seal designed to occupy minimal radial and axial space without compromising seal integrity. The very short axial length of the seal means space saving in the equipment. As the seal does not require axial compression, the fitting becomes a very simple procedure.

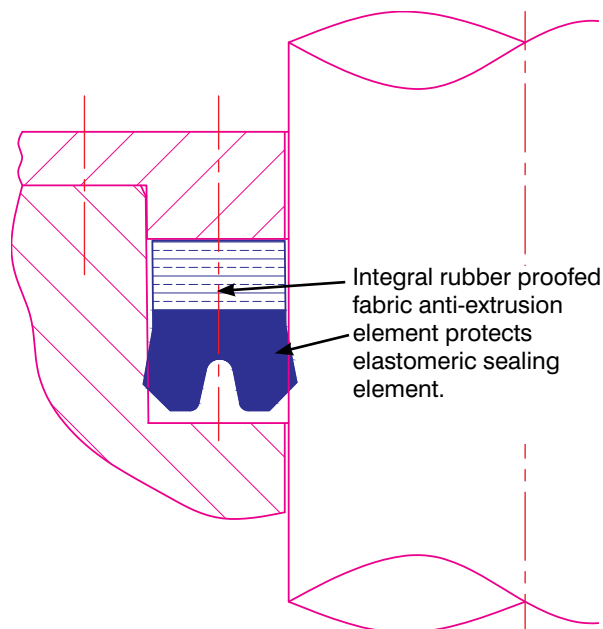

Solosele® G features a profiled elastomeric sealing element that is firmly protected by an integral anti-extrusion element of rubber-proofed fabric. The elastomeric element provides a low-pressure seal by means of radial squeeze, and is pressure responsive for maintaining sealing force at very high pressures — even when there is significant rod misalignment.

The tough integral fabric/rubber base resists extrusion whilst being sufficiently flexible to allow recess fitting in the majority of cases.

**Special features**

Compact seal with excellent high and low pressure sealing capabilities.

Excellent extrusion resistance for long operational life.

Simple to fit — as the seal does not need axial compression.

Cost savings through reduced housing groove requirements.

Available as **Solosele® G-AE** with separate triangular base ring (external or internal) of PTFE, nylon, acetal, etc, to reduce friction or limit seal contact area for short-stroke applications. A corner of the standard base ring is chamfered to accept the additional triangular ring.

Available as '**odd-legged**' design to prevent excessive axial movement within the housing. This prevents pumping of fluid under the seal lip on low-pressure rod retraction.

James Walker worldwide support and distribution

James Walker & Co

Tel: +44 (0)1270 536000
Fax: +44 (0)1270 536100
Email: csc@jameswalker.biz

James Walker Australia

Tel: +61 (0)2 9721 9500
Fax: +61 (0)2 9721 9580
Email: sales.au@jameswalker.biz

James Walker Benelux

(Belgium)
Tel: +32 3 820 7900
Fax: +32 3 828 5484
Email: sales.be@jameswalker.biz
(Netherlands)
Tel: +31 (0)186 633111
Fax: +31 (0)186 633110
Email: sales.nl@jameswalker.biz

James Walker Brasil

Tel: +55 21 2220 2152
Fax: +55 21 2531 1704
Email: sales.br@jameswalker.biz

James Walker China

Tel: +86 21 6876 9351
Fax: +86 21 6876 9352
Email: sales.cn@jameswalker.biz

James Walker Deutschland

Tel: +49 (0)40 386 0810
Fax: +49 (0)40 389 3230
Email: sales.de@jameswalker.biz

James Walker France

Tel: +33 (0)437 497 480
Fax: +33 (0)437 497 483
Email: sales.fr@jameswalker.biz

James Walker Iberica

Tel: +34 94 447 0099
Fax: +34 94 447 1077
Email: sales.es@jameswalker.biz

James Walker Ireland

Tel: +353 (0)21 432 3626
Fax: +353 (0)21 432 3623
Email: sales.ie@jameswalker.biz

James Walker Italiana

Tel: +39 02 257 8308
Fax: +39 02 263 00487
Email: sales.it@jameswalker.biz

James Walker Mfg Co. (USA)

Tel: +1 708 754 4020
Fax: +1 708 754 4058
Email: sales.jwvmfg.us@jameswalker.biz

James Walker New Zealand

Tel: +64 (0)9 272 1599
Fax: +64 (0)9 272 3061
Email: sales.nz@jameswalker.biz

James Walker Norge

Tel: +47 22 706800
Fax: +47 22 706801
Email: sales.no@jameswalker.biz

James Walker Oil & Gas (USA)

Tel: +1 281 875 0002
Fax: +1 281 875 0188
Email: oilandgas@jameswalker.biz

James Walker Singapore

Tel: +65 6777 9896
Fax: +65 6777 6102
Email: sales.sg@jameswalker.biz

James Walker South Africa

Tel: +27 (0)31 304 0770
Fax: +27 (0)31 304 0791
Email: sales.za@jameswalker.biz

Health warning: If PTFE or fluoroelastomer (eg, FKM, FFKM, FEPM) products are heated to elevated temperatures, fumes will be produced which may give unpleasant effects, if inhaled. Whilst some fumes are emitted below 250°C from fluoroelastomers or below 300°C from PTFE, the effect at these temperatures is negligible. Care should be taken to avoid contaminating tobacco with particles of PTFE or fluoroelastomer, or with PTFE dispersion, which may remain on hands or clothing. Material Safety Data Sheets (MSDS) are available on request.

Information in this publication and otherwise supplied to users is based on our general experience and is given in good faith, but because of factors which are outside our knowledge and control and affect the use of products, no warranty is given or is to be implied with respect to such information. Unless governed by type approval or contract, specifications are subject to change without notice. Statements of operating limits quoted in this publication are not an indication that these values can be applied simultaneously.

To ensure you are working with the very latest product specifications, please consult the relevant section of the James Walker website: www.jameswalker.biz.

James Walker & Co Ltd

Metallurgical Industry Support Team
1 Millennium Gate, Westmere Drive
Crewe, Cheshire CW1 6AY, UK
Tel: +44 (0)1270 536090
Fax: +44 (0)1270 536100
Email: metal@jameswalker.biz

www.jameswalker.biz



CERTIFICATE No. FM 01269
BS EN 9100:2003
BS EN ISO 9001:2008